



USB 3.2 Gen 1 Extender Box to Box EUB-220



User Manual Version 1.0

Thank You for Purchasing This Product

For optimum performance and safety, please read these instructions carefully before connecting, operating or adjusting this product. Please keep this manual for future reference.

Surge Protection Device Recommended

This product contains sensitive electrical components that may be damaged by electrical spikes, surges, electric shock, lightning strikes, etc. Use of surge protection systems is highly recommended in order to protect and extend the life of your equipment.

Caution

The use of CAT6A F/FTP 23AWG cable is recommended. Please connect in direct interconnection method and do not cross connect.

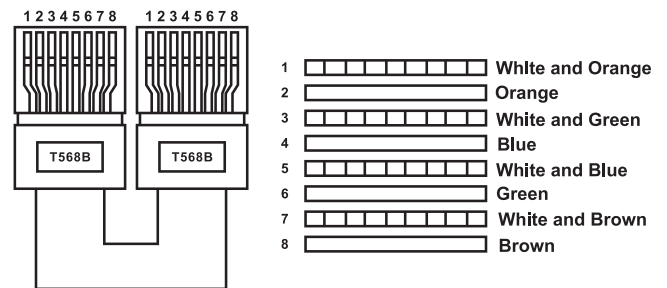

Direct Interconnection Method

Table of Contents

Section and Topic	Page
1. Introduction.....	1
2. Features.....	1
3. Package Contents.....	2
4. Specifications.....	2
5. Operation Controls and Functions.....	3
5.1 Transmitter Panel.....	3
5.2 Receiver Panel.....	4
6. API Commands.....	5, 6, 7
7. Application Example.....	8

1. Introduction

This USB Extender can extend USB 3.2 Gen 1 5Gbps signal to a distance up to 100m/328ft via a single CAT6a cable. The transmitter features one USB-C and one USB-B selectable input ports. The receiver features one USB-C and three USB-A device ports. Bi-directional 24V PoC (Power over Cable) function allows user to only supply power to either the transmitter or the receiver. It can be widely used for long distance USB signal transmission between USB sources and devices like webcams, PTZ cameras, keyboards, mouse devices, USB microphones, flash sticks, printers, scanners, touch panel displays and other USB devices.

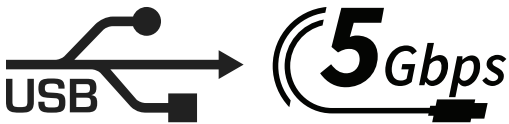

2. Features

- ⌚ Extension of USB 3.2 Gen 1 up to 100m/328ft via CAT6a cable
- ⌚ USB 3.2 Gen 1 connectivity with data transfer rate up to 5Gbps
- ⌚ Backwards compatible with USB 2.0 and 1.1
- ⌚ Hardware acceleration for isochronous and bulk transfer
- ⌚ TX features 1x USB-B and 1x USB-C selectable input ports
- ⌚ Support auto switching and manual switching modes
- ⌚ RX features 1x USB-C and 3x USB-A output ports (2x 5V@1A and 2x 5V@1.5A)
- ⌚ Support RS-232 pass-through and API control
- ⌚ Support firmware upgrade via USB-C service port
- ⌚ Support FSYNC GPIO pass-through for industry camera use
- ⌚ Support bi-directional 24V PoC (Power over Cable), when TX or RX gets power, the other end does not need an external power supply
- ⌚ Plug-and-play with no drivers, downloads, or software required

3. Package Contents

- ⊗ Transmitter (1 piece)
- ⊗ Receiver (1 piece)
- ⊗ 24V/3.75A Power Supply (1 piece)
- ⊗ 4pin-3.5mm Male Phoenix Connector (2 piece)
- ⊗ Mounting Ear (4 piece)
- ⊗ KM3*4 Machine Screw (8 piece)
- ⊗ User Manual (1 piece)

4. Specifications

Technical	
USB Protocol	USB 3.2 Gen 1
Transmission Rate	Up to 5Gbps
Transmission Distance	100m/328ft via CAT6a (F/FTP) cable, 1.5m/4.9ft via USB cable
ESD Protection	IEC 61000-4-2: ±8kV (Air-gap discharge), ±4kV (Contact discharge)
Connections	
Transmitter	Input: 1× USB-C IN (Female), 1× USB-B IN (Female) Output: 1x USB-C OUT (Female), 2x USB-A OUT (Female), 1× HDBT-USB3 (RJ45) Control: 1× RS-232 (3-pin Phoenix), FSYNC (1-pin Phoenix), 1x SERVICE (USB-C)
Receiver	Input: 1× HDBT-USB3 (RJ45) Output: 3x USB-A (Female), 1x USB-C (Female) Control: 1× RS-232 (3-pin Phoenix), FSYNC (1-pin Phoenix), 1x SERVICE (USB-C)
Mechanical	
Housing	Metal Enclosure
Color	Black
Dimensions	Transmitter / Receiver: 140mm [W] × 75mm [D] × 23mm [H]
Weight	Transmitter: 313g; Receiver: 318g
Power Supply	Input: AC 100~240V 50/60Hz; Output: DC 24V/3.75A
Power Consumption	Transmitter: 23W (Max); Receiver: 35W (Max)
Operating Temperature	0°C ~ 40°C / 32°F ~ 104°F
Storage Temperature	-20°C ~ 60°C / -4°F ~ 140°F
Operating Humidity	20%~80% relative humidity, non-condensing
Storage Humidity	10%~90% relative humidity, non-condensing

5. Operation Controls and Functions

5.1 Transmitter Panel

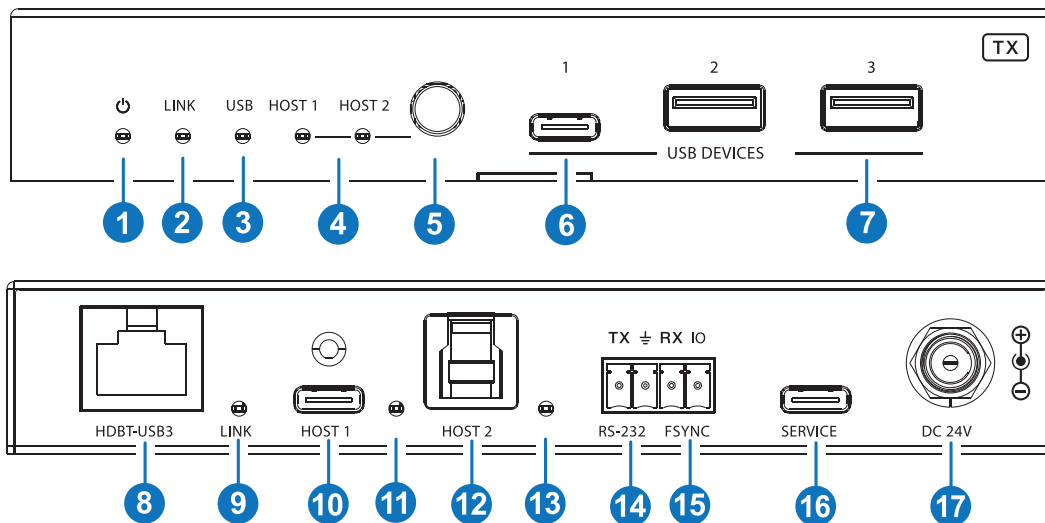

Num.	Name	Function Description
1	Power LED	The LED will be on when the transmitter is powered on.
2	Link LED	Connection Signal Indicator On: Transmitter and Receiver are connected and linked. Off: Transmitter and Receiver are not connected.
3	USB LED	USB signal indicator On: USB 3 signal is detected. Blinking: USB 2 signal is detected. Off: USB signal is not detected.
4	Host (1~2) LED	When HOST 1/2 is selected, the corresponding LED will be on.
5	Host Switch Button	Press this button to switch between HOST 1 and HOST 2.
6	USB Devices (1)	Downlink USB-C port, connected to USB devices such as U disk or hard disk. Its output power is up to 5V/1A.
7	USB Devices (2~3)	Downlink USB-A port, connected to USB devices such as U disk or hard disk. Its output power is up to 5V/1A.
8	HDBT-USB3	Connects to the HDBT-USB3 port on Receiver with CAT6a cable.
9	Link LED	Connection signal indicator On: Transmitter and Receiver are connected and linked. Off: Transmitter and Receiver are not connected.
10	Host 1	Uplink USB-C port, connected to a PC or host. It can be used to update HUB firmware.
11	Host 1 LED	The LED will be on when USB signal is detected on HOST 1 port.
12	Host 2	Uplink USB-B port, connected to a PC or host. It can be used to update HUB firmware.
13	Host 2 LED	The LED will be on when USB signal is detected on HOST 2 port.
14	RS-232	3pin phoenix connector, connected to a PC or control system for RS-232 command pass-through.
15	FSYNC	FSYNC port, the level pass through from Transmitter to Receiver, to synchronize the external devices. Default level range is 0~5V.
16	SERVICE	Firmware update port, supporting USB 2.0.
17	DC 24V	DC 24V/3.75A power input port.

5. Operation Controls and Functions

5.2 Receiver Panel

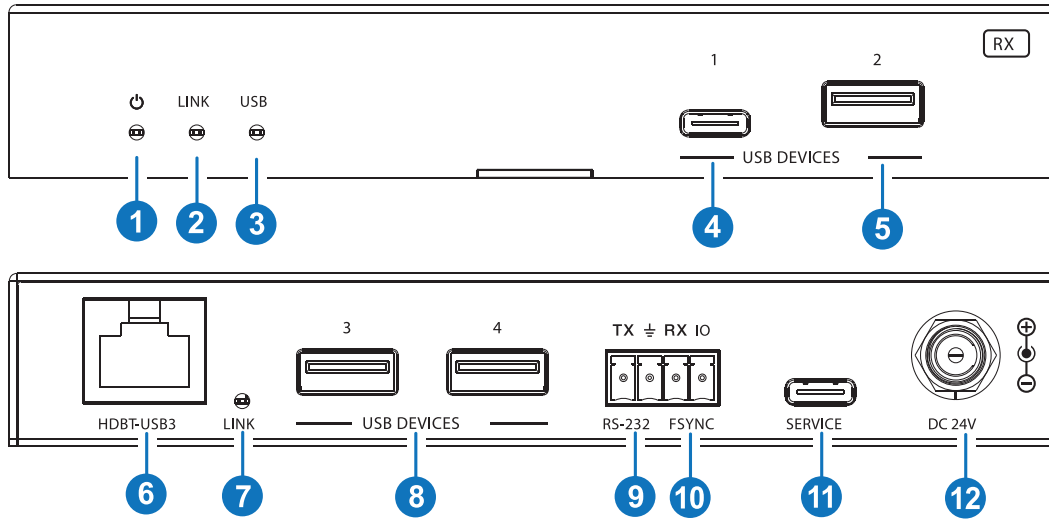

Num.	Name	Function Description
1	Power LED	The LED will be on when the transmitter is powered on.
2	Link LED	Connection Signal Indicator On: Transmitter and Receiver are connected and linked. Off: Transmitter and Receiver are not connected.
3	USB LED	USB signal indicator On: USB 3 signal is detected. Blinking: USB 2 signal is detected. Off: USB signal is not detected.
4	USB Devices (1)	Downlink USB-C port, connected to USB devices such as U disk or hard disk. Its output power is up to 5V/1A.
5	USB Devices (2)	Downlink USB-A port, connected to USB devices such as U disk or hard disk. Its output power is up to 5V/1A.
6	HDBT-USB3	Connects to the HDBT-USB3 port on Receiver with CAT6a cable.
7	Link LED	Connection signal indicator On: Transmitter and Receiver are connected and linked. Off: Transmitter and Receiver are not connected.
8	USB Devices (3~4)	Downlink USB-A port, connected to USB devices such as U disk or hard disk. Its output power is up to 5V/1A.
9	RS-232	3-pin phoenix connector, connected to a PC or control system for RS-232 command pass-through.
10	FSYNC	FSYNC port, the level pass-through from Transmitter to Receiver, to synchronize external devices. Def. 0~5V
11	Service	Firmware update port, supporting USB 2.0.
12	DC 24V	DC 24V/3.75A power input port.

6. API Commands

The product supports API commands control. Connect the SERVICE or RS-232 port of the product to a PC, then open a Serial Command tool on PC to send API commands to control the product. The API commands list is shown below.

ASCII Commands				
1. Service port (USB-C virtual RS-232) communication protocol (Internal debug) Baud rate: 115200 (fixed), Data bit: 8, Stop bit: 1, Parity bit: none The end mark of command is "<CR><LF>"				
2. Phoenix RS-232 port communication protocol (Connect to control system) Baud rate: 4800~115200 (configurable), Data bit: 8, Stop bit: 1, Parity bit: none The end mark of command is "<CR><LF>"				
Command	Function	Example	Feedback	Default
?	Get the list of all commands	?		
help	Get the list of all commands	help		
get fw version	Get firmware version	get fw version	1.0.0	
set reboot	Reboot the device	set reboot	Reboot... System Initializing... Initialization Finished! FW: 1.0.0	
set reset	Reset to factory defaults	set reset	Sure to RESET to default settings? Type "Yes" after next prompt to confirm...	
get status	Get system status	get status	Please refer to the note at the end of the list.	
set key on/off	Set front panel key on/off	set key on set key off	Set key on Set key off	on
get key	Get front panel key on/off status	get key	Key on	
set baud x	Set RS-232 baud rate to x bps x=1: 4800 x=2: 9600 x=3: 19200 x=4: 38400 x=5: 57600 x=6: 115200	set baud 6	Set baud rate 115200	115200
get baud	Get RS-232 baud rate	get baud	Baud rate 115200	

Command	Function	Example	Feedback	Default
set input x	Set USB host input port (x=1~2) x=1: USB host 1 (USBB) x=2: USB host 2 (USBC)	set input 1	Set input USB host 1	1
get input	Get USB host input port	get input	Input USB host 1	
get usb5v x	Get USB host input port 5V (x=0~2) x=0: all USB host inputs x=1: USB host 1 (USBB) x=2: USB host 2 (USBC)	get usb5v 0	USB host 1: 5V USB host 2: none	
set autoswitch x	Set auto-switching on/off (USB 5V detection) x=On, Off	set autoswitch on	Set autoswitch on	on
get autoswitch	Get auto-switching status	get autoswitch	Autoswitch on	
set tx usbd x power y	Set TX USB device ports (x=0~2) power to (y=0~2) x=0: TX all USB device ports x=1: TX USB device 1 (USBA) x=2: TX USB device 2 (USBA) y=0: Force power off y=1: Follow USB host power y=2: Force power on	set tx usbd 0 power 1	Set TX all USB device ports power follow USB host power	1
get tx usbd x power	Get TX USB device ports (x=0~2) power status x=0: TX all USB device ports x=1: TX USB device 1 (USBA) x=2: TX USB device 2 (USBA)	get tx usbd 0 power	TX all USB device ports power follow USB host power	
set rx usbd x power y	Set RX USB device ports (x=0~4) power to (y=0~2) x=0: RX all USB device ports x=1: RX USB device 1 (USBA) x=2: RX USB device 2 (USBC) x=3: RX USB device 3 (USBA) x=4: RX USB device 4 (USBA) y=0: Force power off y=1: Follow USB host power y=2: Force power on	set rx usbd 0 power 1	Set RX all USB device ports power follow USB host power	1
set hdbt update	Set service port to HDBT UART for FW update	set hdbt update	HDBT update	

Command	Function	Example	Feedback	Default
get rx usbd x power	Get RX USB device ports (x=0~4) power status x=0: RX all USB device ports x=1: RX USB device 1 (USBA) x=2: RX USB device 2 (USBC) x=3: RX USB device 3 (USBA) x=4: RX USB device 4 (USBA)	get rx usbd 0 power	RX all USB device ports power follow USB host power	

Note: The feedback of the command of “get status” is as follow. (The middle line ends with <LF><CR> and the last line ends with <CR><LF>.)

```

=====
Status Info 2-Port USB 3.2 Gen 1 Extender
TX_FW 1.0.0 RX_FW 1.0.0

Source   Key       Baud      Autoswitch
01       On        115200    On

Input    USB_Power
01       5V
02       None

Output   USB_Power
TX_01    Follow_Input
TX_02    Follow_Input
RX_01    Follow_Input
RX_02    Follow_Input
RX_03    Force_Off
RX_04    Force_On
=====

```

7. Application Example

